

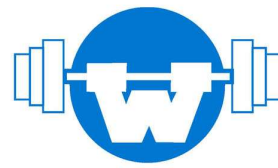

# Specification Sheet



## WEIGHTLIFTER

WHERE QUALITY, HONESTY & SERVICE COME FIRST

### MONOCOQUE ALLOY TIPPER, SLOPING HEADBOARD, STEP FRAME

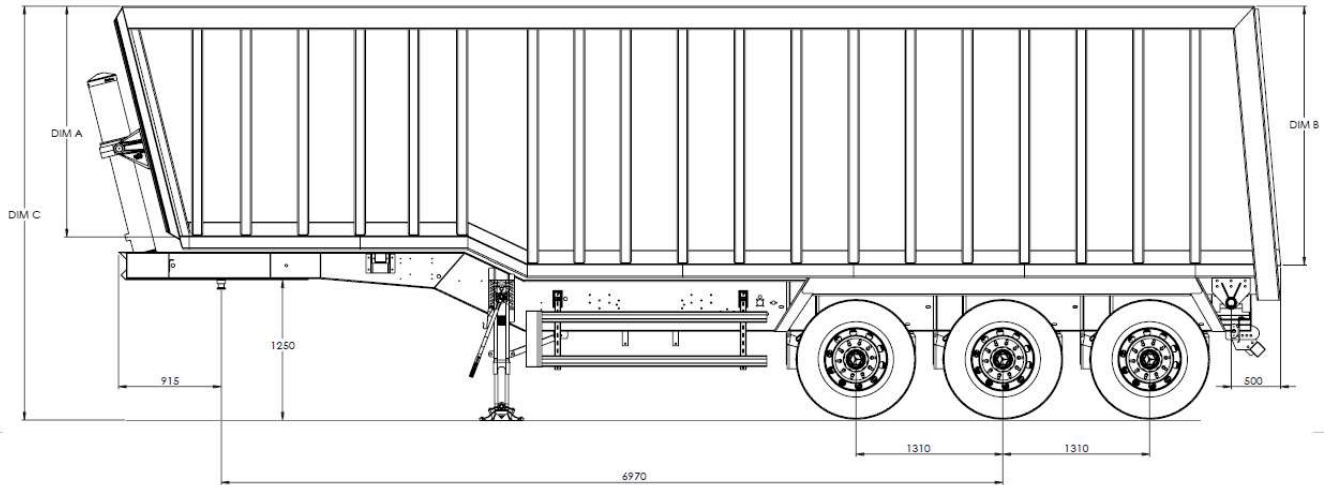

Capacity cu yds (m <sup>3</sup> )	Bulk spec 67 (51.2)	70 (53.5)
A	2015	2112
B	2265	2362
C	3647	3744

Figures refer to a 10.1m frame with a body construction including an air operated, sloping taildoor.

Other dimensions: Total length 10775mm plus catwalk, Total width 2550mm, King Pin to rear 9600mm, Overall rear overhang 600mm  
Plated weights: Gross train weight 39000kg, Axle weight 8000kg, King pin weight 15000kg

#### CHASSIS

Weightlifter Tri-axle 10.1m Step Framed Tipping Trailer Chassis. Manufactured in steel. Fabricated I beam with 4 square section box crossmembers at rear. 2" kingpin, 915mm from front of frame. 1300mm chassis centres and 250mm ride height.

##### Optional

- 10.6m or 11.1m frame length

#### AXLES AND SUSPENSION

JOST DCA TE5/8T 1010 Axles with 22.5 Disc on JOST 9 tonne lightweight air suspension. Cartridge bearings.

##### Optional

- Raise and lower valve. (COLAS), auto reset.
- Lifting front or rear axle automatically raised and lowered by EBS unit.
- Lifting front or rear axle complete with traction aid operated from chassis/cab.
- BPW HSFALU 3/9010-15 HDV 36 SN4218 Drum Brake Axles on BPW 9 tonne tri-axle AL suspension with welded seats
- BPW SHBFALU 3/9010-15 HDV 36 TSB24309 22.5 Disc Brake Axles on BPW 9 tonne tri-axle AL suspension with welded seats

- SAF Intradisc IU25/2000 33 CD Axles with SBS2220 22.5 Disc brakes. SAF 9 tonne tri-axle intra suspension
- SAF Intradrum IU25/2000 33 CD Axles with SNK 420x180 Drum brakes. SAF 9 tonne tri-axle intra suspension.

#### BRAKING SYSTEM

Knorr-Bremse EBS & RSS (Roll Stability System) with auto-spring park brake. Steel air tanks

##### Optional

- Wabco EBS & RSS with auto-spring park brake.
- Alloy air tanks

#### WHEELS AND TYRES

Bridgestone 168 385/65R 22.5 tyres.  
Steel wheels factory painted Silver.

##### Optional

- Alcoa machine finish alloy wheels.
- Alcoa Durabrite finish alloy wheels.
- Xlite machine finished alloy wheels.
- XBrite high-lacquer alloy wheels.

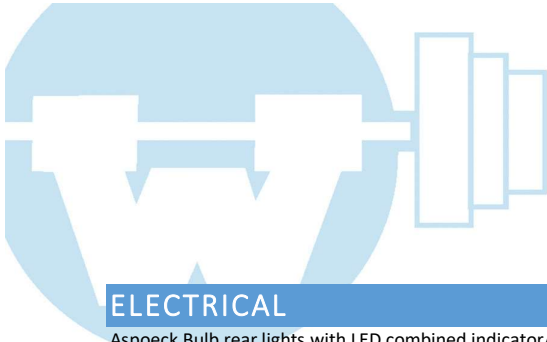

## ELECTRICAL

Aspoeck Bulb rear lights with LED combined indicator/side marker lights.  
Amber Tip Warning Light.

### Optional

- Aspoeck LED strip rear lights with LED combined indicator/side marker lights.
- High intensity reverse/working lights/strobe lights.
- PM 1155 4 digital load cells complete with chassis or in-cab display.
- PM 511 FreeWeigh handheld display.
- PM 1300 4 digital load cells complete with cab display and reverse camera.
- VWS 4 digital load cell Weighing System, complete with chassis or cab display.
- VWS 4 digital load cell Weighing System, complete with cab display and reverse camera.
- Additional Camera.
- VWS Handheld Display.

## TIPPING GEAR

Edbro CS1700/5/7233 short outer cover ram assembly.

### Optional

- Hyva FC169/5/7130K1050 short outer cover ram assembly.
- Edbro CS 1700/5/7233 full outer cover ram assembly. (Vertical Headboard)
- Hyva FC 169/5/7130 full outer cover ram assembly. (Vertical Headboard)

## CHASSIS ANCILLARIES

Jost Modul B0201 geared landing legs with compensating feet.  
Alloy side guards.

Steel rear under-run.

Spray suppression to suit European Whole Vehicle Type Approval legislation.

### Optional

- Chassis set up for air locking door switched on chassis side.
- Chassis set up for air locking door switched from in cab.
- Towing Eyes.
- Toolbox JBX65
- Toolbox JBX100.
- Reverse Buzzer.
- Lashing Rings.
- Internal LED Body Light switched on chassis.
- Fast-Fit plastic wings.

## BODY

Weightlifter monocoque construction.

Headboard sloping forward 14 degrees, constructed in 4.76mm alloy plate and extruded I beams as lifting channel to suit short outer cover ram assembly.

Floor constructed with 6.35 mm alloy plate with rearmost sheet in 8mm on 100mm x 100mm extruded alloy cross members and rubber blocks. 250mm x 75mm alloy stub channels. 10mm rear crossmember.

Sides constructed with 4.76mm alloy plate sides pressed to form bottom rails, with pressed pillars stitch welded to outside.

Vertical taildoor constructed using 4.76mm alloy plate with pressed framing. Outside fitting and rubber sealed. Externally hung at top from 150mm x 75mm alloy channel using x4 single action alloy hinges.

Secured at bottom with 25mm diameter high tensile steel locking bar with loop type handles and ramp fasteners to each side.

### Optional

- Alternative capacities.
- Vertical headboard
- Reversed top rails body flush to outside.
- Rearmost 5715mm (NTR) 6602mm (RTR) of floor in 6mm Endural ilo 8mm alloy.
- Internal wear plates to sides.
- Taildoor sloping forward 5°, secured at bottom with air actuated, internal or external 25mm diameter high tensile steel locking. (see chassis ancillaries)
- Additional ramp fasteners to bottom of taildoor.
- Name board on top half of taildoor.

## ACCESS

Body mounted alloy viewing ladder

Gusseted tube type steps inside body to correspond with external access

### Optional

- Body mounted full width catwalk with access step.
- Delete internal steps.
- Exterior prop with ladder to suit stored under body offside.

## BODY ANCILLARIES

Headboard mounted shovel and storage rack

Conspicuity markings included.

## SHEETER SYSTEMS

### Optional

- Full range of Dawbarn side-to-side, flip and gull-wing sheeting systems.
- Weightlifter Bodies, Harsh and Shur-Co options also available.

## PAINT

Gloss painted chassis in two pack.

Unpainted body.

One year paint warranty.

### Optional

- Gloss painted body

Depending on trailer configuration, certain options may not be possible. For further information, please contact Weightlifter Bodies Ltd. Pictures and technical information are not binding and are subject to modification without prior notice.

Feb 2021 Issue 1.