

# WEIGHTLIFTER

WHERE QUALITY, HONESTY & SERVICE COME FIRST

## Specification Sheet

### BULK STEEL MONOCOQUE TIPPER, SLOPING HEADBOARD, STEP FRAME

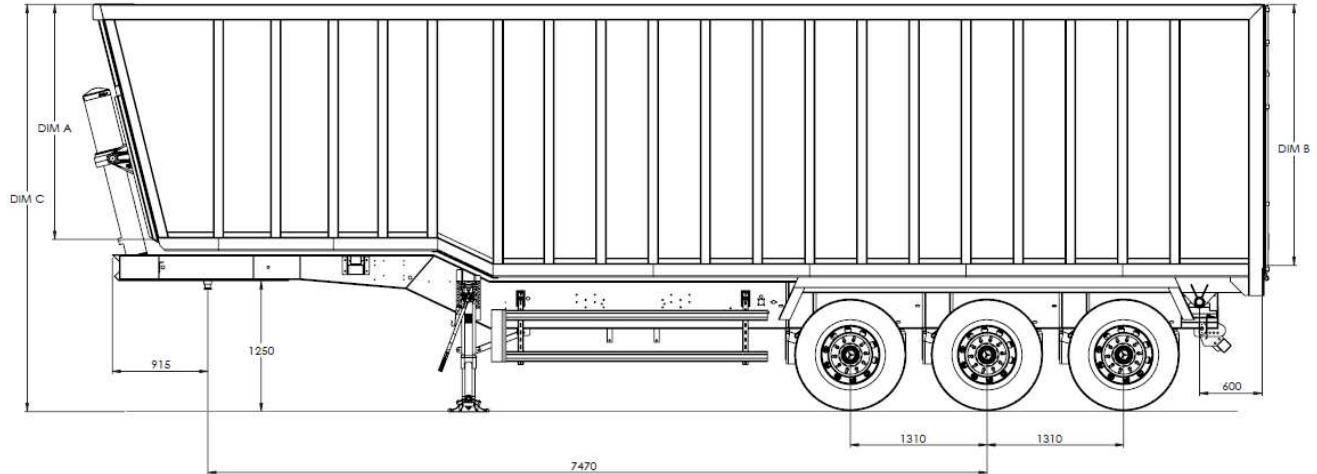

Capacity	cu yds (m <sup>3</sup> )	75 (57.3)	80 (61.2)	75 (57.3)	80 (61.2)
Sheet system		Flip		Side to side or gull wing	
A		2222	2377	2125	2270
B		2472	2627	2375	2520
C		3867	4022	3370	3915

Figures refer to a 10.6m frame. Body width reduces for flip sheet.

Other dimensions: Total length 11430mm plus catwalk, Total width 2550mm, King Pin to rear 10133mm, Rear overhang 600mm  
Plated weights: Gross train weight 39000kg, Axle weight 8000kg, King pin weight 15000kg

### CHASSIS

Weightlifter Triaxle 10.6m Step Framed Tipping Trailer Chassis. Manufactured in steel. Fabricated I beam with 4 square section box crossmembers at rear. 2" kingpin, 915mm from front of frame. 1300mm chassis centres and 250mm ride height.

#### Optional

- 10.1m or 11.1m frame length

### AXLES AND SUSPENSION

JOST DCA TE5/8T 1010 Axles with 22.5 Disc on JOST 9 tonne lightweight air suspension. Cartridge bearings.

#### Optional

- Raise and lower valve. (COLAS), auto reset.
- Lifting front or rear axle automatically raised and lowered by EBS unit.
- Lifting front or rear axle complete with traction aid operated from chassis/cab.
- BPW HSFALU 3/9010-15 HDV 36 SN4218 Drum Brake Axles on BPW 9 tonne tri-axle AL suspension with welded seats
- BPW SHBFALU 3/9010-15 HDV 36 TSB24309 22.5 Disc Brake Axles on BPW 9 tonne tri-axle AL suspension with welded seats
- SAF Intradisc IU25/2000 33 CD Axles with SBS2220 22.5 Disc brakes. SAF 9 tonne tri-axle intra suspension

- SAF Intradrum IU25/2000 33 CD Axles with SNK 420x180 Drum brakes. SAF 9 tonne tri-axle intra suspension.

### BRAKING SYSTEM

Knorr-Bremse EBS & RSS (Roll Stability System) with auto-spring park brake. Steel air tanks

#### Optional

- Wabco EBS & RSS with auto-spring park brake.
- Alloy air tanks

### WHEELS AND TYRES

Bridgestone 168 385/65R 22.5 tyres. Steel wheels factory painted Silver.

#### Optional

- Alcoa machine finish alloy wheels.
- Alcoa Durabrite finish alloy wheels.
- Xlite machine finished alloy wheels.
- XBrite high-lacquer alloy wheels.

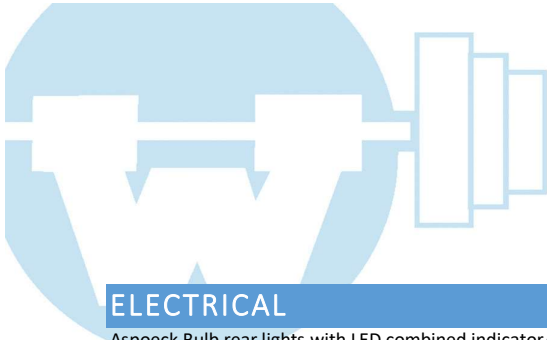

## ELECTRICAL

Aspoeck Bulb rear lights with LED combined indicator/side marker lights.  
Amber Tip Warning Light.

### Optional

- Aspoeck LED strip rear lights with LED combined indicator/side marker lights.
- High intensity reverse/working lights/strobe lights.
- PM 1155 4 digital load cells complete with chassis or in-cab display.
- PM 511 FreeWeigh handheld display.
- PM 1300 4 digital load cells complete with cab display and reverse camera.
- VWS 4 digital load cell Weighing System, complete with chassis or cab display.
- VWS 4 digital load cell Weighing System, complete with cab display and reverse camera.
- Additional Camera.
- VWS Handheld Display.

## TIPPING GEAR

Edbro CS1700/5/7233 short outer cover ram assembly.

### Optional

- Hyva FC169/5/7130K1050 short outer cover ram assembly.
- Edbro CS 1700/5/7233 full outer cover ram assembly. (Vertical Headboard)
- Hyva FC 169/5/7130 full outer cover ram assembly. (Vertical Headboard)

## CHASSIS ANCILLARIES

Jost Modul B0201 geared landing legs with compensating feet.  
Alloy side guards.

Weightlifter steel rear under-run.

Spray suppression to suit European Whole Vehicle Type Approval legislation.

### Optional

- Towing Eyes.
- Toolbox JBX65
- Toolbox JBX100.
- Reverse Buzzer.
- Lashing Rings.
- Internal LED Body Light switched on chassis.
- Fast-Fit plastic wings.

## BODY

Weightlifter pressed steel tipper body built with Swedish Steel Hardox® 450. Monocoque construction. Floor constructed from Hardox® 450 5mm pressed plate 100x100x4 crossmembers in line with side pillars.

Sides constructed with Hardox® 450 4mm, pressed to form bottom rails. Heavy duty top rails. Pressed steel pillars stitch welded at 500mm centres. Headboard sloping forward 14 degrees, constructed using 4mm Hardox plate, with 180x75 timber filled lifting channels to suit front mount ram assembly. Pressed external top rail.

Interlocking Barn Doors, constructed using 4mm Hardox 450 plate, Split 50/50 and hung on 5 hinges per door. Doors open to 270°.

Secured at top with manual over centre catch.

Secured at bottom with manually operated 25mm diameter high tensile steel locking bar with loop type handles.

Hooks and rings to secure doors in open position.

### Optional

- Vertical headboard
- Box section side pillars ilo pressed steel
- 5x or 3x floor impact angles
- Universal taildoor arrangement.
- Name board on top half of taildoor.

## ACCESS

### Optional

- Body mounted full width catwalk with access step.
- Body mounted alloy viewing ladder
- Gusseted tube type steps inside body to correspond with external access

## BODY ANCILLARIES

Conspicuity markings included.

### Optional

- Headboard mounted shovel and storage rack

## SHEETER SYSTEMS

### Optional

- Full range of Dawbarn side-to-side, flip and gull-wing sheeting systems.
- Weightlifter Bodies, Harsh and Shur-Co options also available.

## PAINT

Gloss painted chassis in two pack.

Unpainted body.

One year paint warranty.

### Optional

- Gloss painted body

Depending on trailer configuration, certain options may not be possible. For further information, please contact Weightlifter Bodies Ltd. Pictures and technical information are not binding and are subject to modification without prior notice.

Feb 2021 Issue 1.