

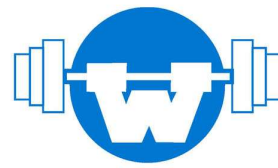

Specification Sheet



WEIGHTLIFTER

WHERE QUALITY, HONESTY & SERVICE COME FIRST

ALUMINIUM HALF BARREL TRAILER, STRAIGHT FRAME

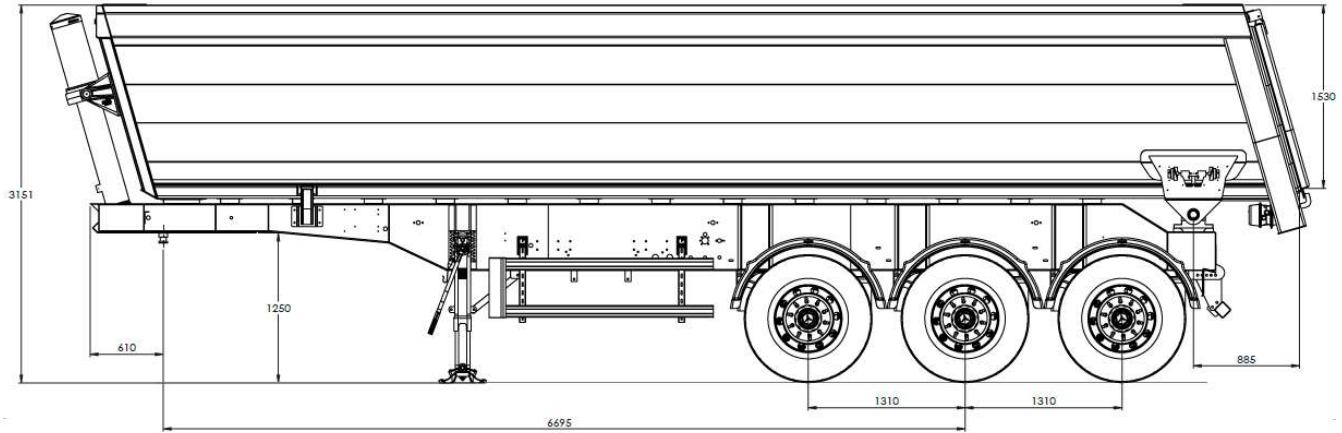

Other dimensions: Overall width 2550mm, Overall length 10525mm excluding catwalk, Internal height 1530mm
Plated weights: Gross train weight 39000kg, Axle weight 8000kg, King pin weight 15000kg

CHASSIS

Weightlifter Triaxle 9.4m Straight Framed Tipping Trailer Chassis. Manufactured in steel. Fabricated I beam with four torsional box section crossmembers at rear. 2" kingpin, 610mm from front of frame. 1300mm chassis centres and 400mm ride height, suitable for road laying operation. Suitable for 44000kg operation.

AXLES

JOST DCA TE5/8T 1015 Axle with 22.5 Disc on JOST 9 tonne lightweight air suspension. Cartridge bearings.

Optional

- Raise and lower valve. (COLAS), auto reset.
- Lifting front axle automatically raised and lowered by EBS unit.
- Lifting front axle complete with traction aid operated from chassis/cab.
- BPW HSFALM 3/9010-15 HDV 36 SN4218 Drum Brake Axles on BPW 9 tonne tri-axle AL suspension with welded seats
- BPW SHBFALM 3/9010-15 HDV 36 TSB24309 22.5 Disc Brake Axles on BPW 9 tonne tri-axle AL suspension with welded seats
- SAF Intradisc I040/3005 42 & I040/2505 42CD Axles with SBS2220 22.5 Disc brakes. SAF 9 tonne tri-axle intra suspension
- SAF Intradrum I040/3005 42 & I040/2505 42CD Axles with SNK 420x180 Drum brakes. SAF 9 tonne tri-axle intra suspension.

BRAKING SYSTEM

Knorr-Bremse EBS & RSS (Roll Stability System) with auto-spring park brake. Steel air tanks

Optional

- Wabco EBS & RSS with auto-spring park brake.
- Alloy air tanks

WHEELS AND TYRES

Bridgestone 168 385/65R 22.5 tyres.
Steel wheels factory painted Silver.

Optional

- Alcoa machine finish alloy wheels.
- Alcoa Durabrite finish alloy wheels.
- Xlite machine finished alloy wheels.
- XBrite high-lacquer alloy wheels.

ELECTRICAL

Aspoeck Bulb rear lights with LED combined indicator/side marker lights. Amber Tip Warning Light.

Optional

- Aspoeck LED strip rear lights with LED combined indicator/side marker lights.
- High intensity reverse/working lights/strobe lights.
- PM 1155 4 digital load cells complete with chassis or in-cab display.
- PM 511 FreeWeigh handheld display.
- PM 1300 4 digital load cells complete with cab display and reverse camera.
- VWS 4 digital load cell Weighing System, complete with chassis or cab display.
- VWS 4 digital load cell Weighing System, complete with cab display and reverse camera.
- Additional Camera.
- VWS Handheld Display.

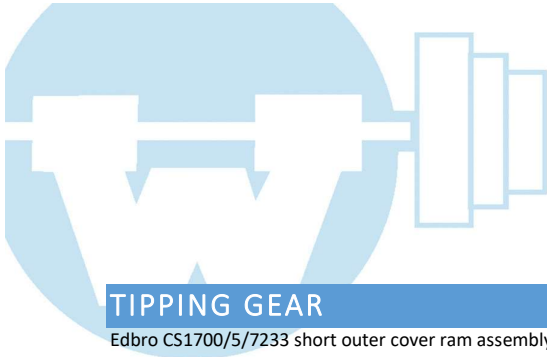

TIPPING GEAR

Edbro CS1700/5/7233 short outer cover ram assembly.

Optional.

- Hyva FC169/5/7130K1050 short outer cover ram assembly.

CHASSIS ANCILLARIES

Jost Modul B0201 geared landing legs with compensating feet.

Alloy side guards.

Weightlifter Steel rear under-run.

Fast fit plastic wings.

Spray suppression to suit European Whole Vehicle Type Approval legislation.

Optional

- Chassis set up for air locking door switched on chassis side.
- Chassis set up for air locking door switched from in cab.
- Towing Eyes.
- Toolbox JBX65
- Toolbox JBX100.
- Reverse Buzzer.
- Lashing Rings.
- Internal LED Body Light switched on chassis.
- Remove under-run (subject to exemption)

BODY

Weightlifter pressed alloy tipper body. 40cu yd capacity.

Headboard constructed with a single piece 4.76mm aluminium plate sloping forward 16 degrees built to suit short outer cover hydraulic tipping ram.

Extruded lifting I beams, internal and external pressed top rails.

Floor constructed with a single piece pressed 8mm aluminium plate on pressed long runners & rubber blocks.

Sides constructed with a single piece each pressed 4.76mm aluminium plate. Pressed to form self-draining top rail.

Taildoor constructed using 4.76mm alloy plate with pressed framing. Outside fitting and rubber sealed. Sloping forward 16 degrees. Hung at top from 150mm x 75mm alloy channel using x4 single action alloy hinges.

Secured at bottom with a manual 25mm diameter high tensile steel locking bar.

No Insulation.

Optional

- Ramp fasteners to bottom of taildoor.
- Name board on top half of tail door.
- Double action hinges with anti-lift angles to both sides of door.
- Weightlifter closing plates to rear hinge.
- Door secured at bottom with air actuated internal 25mm diameter high tensile steel locking bar
- Quicksilver lining

ACCESS

Body mounted alloy viewing ladder

Gusseted tube type steps inside body to correspond with external access

Optional

- Body mounted full width catwalk with access step.
- Delete internal steps.
- Exterior prop with ladder to suit stored under body offside.
- Rear access pull-out ladder.

BODY ANCILLARIES

Headboard mounted shovel and storage rack

Conspicuity markings included.

SHEETER SYSTEMS

Optional

- Full range of Dawbarn side-to-side, flip and gull-wing sheeting systems.
- Weightlifter Bodies, Harsh and Shur-Co options also available.

PAINT

Gloss painted chassis in two pack.

Unpainted body.

One year paint warranty.

Optional

- Gloss painted body

Depending on trailer configuration, certain options may not be possible. For further information, please contact Weightlifter Bodies Ltd. Pictures and technical information are not binding and are subject to modification without prior notice.

Feb 2021 Issue 1.